

PRUŽINY

Tažné pružiny

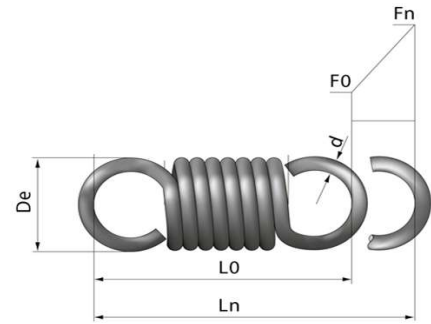

| TAŽNÉ PRUŽINY | | | | | | | |
|----------------------------|--------------------------------------|---|--|-------------------------|--|--------------------------------|------|
| Průměr drátu d (mm) | Vnější průměr pružiny De (mm) | Délka pružiny v nezátženém stavu Lo (mm) | Prodloužení pružiny při max. deformaci Ln - Lo (mm) | Počet z závitů z | Síla potřebná pro max. deformaci pružiny Fn (N) | Tuhost pružiny c (N/mm) | |
| 0,5 | 2,5 | 7,9 | 1,71 | 10 | 16,1 | 7,98 | |
| | | 10,9 | 2,74 | 16 | | 4,98 | |
| | | 15,4 | 4,28 | 25 | | 3,19 | |
| | 3,5 | 9,5 | 4,32 | 10 | 12,0 | 2,35 | |
| | | 12,5 | 6,91 | 16 | | 1,47 | |
| | | 17,0 | 10,80 | 25 | | 0,94 | |
| | | 24,5 | 17,30 | 40 | | 0,59 | |
| | | 290,0 | 210,00 | 60 | | 0,05 | |
| | | 5,5 | 12,7 | 13,10 | | 10 | 7,8 |
| | 15,7 | 20,90 | 16 | 0,31 | | | |
| | 20,2 | 32,70 | 25 | 0,21 | | | |
| | 27,7 | 52,30 | 40 | 0,13 | | | |
| | 37,7 | 78,40 | 60 | 0,09 | | | |
| | 0,55 | 2,8 | 8,8 | 1,98 | 10 | 19,0 | 8,18 |
| | | | 12,1 | 3,17 | 16 | | 5,11 |
| 17,0 | | | 4,96 | 25 | 3,27 | | |
| 3,5 | | 9,9 | 3,68 | 10 | 15,7 | 3,63 | |
| | | 13,2 | 5,89 | 16 | | 2,27 | |
| | | 18,1 | 9,20 | 25 | | 1,45 | |
| | | 26,4 | 14,70 | 40 | | 0,90 | |
| 6,0 | | 13,9 | 14,10 | 10 | 9,5 | 0,58 | |
| | | 17,2 | 22,50 | 16 | | 0,36 | |
| | | 22,1 | 35,10 | 25 | | 0,23 | |
| | | 30,4 | 56,20 | 40 | | 0,15 | |
| | | 41,4 | 84,30 | 60 | | 0,10 | |
| 0,63 | 3,00 | 9,7 | 1,85 | 10 | 26,2 | 12,10 | |
| | | 13,5 | 2,96 | 16 | | 7,51 | |
| | | 19,2 | 4,62 | 25 | | 4,81 | |
| | 4,50 | 12,1 | 5,65 | 10 | 18,3 | 2,77 | |
| | | 15,9 | 9,04 | 16 | | 1,73 | |
| | | 21,6 | 14,10 | 25 | | 1,11 | |
| | | 31,0 | 22,60 | 40 | | 0,70 | |
| | 7,00 | 16,1 | 16,60 | 10 | 12,2 | 0,62 | |
| | | 19,9 | 26,60 | 16 | | 0,39 | |
| | | 25,6 | 41,60 | 25 | | 0,25 | |
| | | 35,0 | 66,50 | 40 | | 0,16 | |
| 47,6 | | 99,70 | 60 | 0,11 | | | |

PRUŽINY

Tažné pružiny

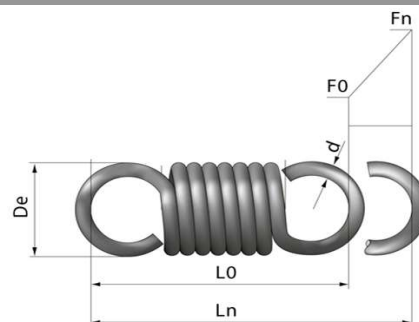

| TAŽNÉ PRUŽINY | | | | | | | |
|----------------------------|--------------------------------------|--|--|-------------------------|--|--------------------------------|-------|
| Průměr drátu d (mm) | Vnější průměr pružiny De (mm) | Délka pružiny v nezátíženém stavu Lo (mm) | Prodloužení pružiny při max. deformaci Ln - Lo (mm) | Počet z závitů z | Síla potřebná pro max. deformaci pružiny Fn (N) | Tuhost pružiny c (N/mm) | |
| 0,7 | 3,5 | 11,1 | 2,36 | 10 | 30,7 | 11,10 | |
| | | 15,3 | 3,78 | 16 | | 6,95 | |
| | | 21,6 | 5,90 | 25 | | 4,44 | |
| | 5,0 | 13,5 | 13,5 | 6,25 | 10 | 22,6 | 3,07 |
| | | | 17,7 | 10,00 | 16 | | 1,92 |
| | | 24,0 | 24,0 | 15,60 | 25 | | 1,23 |
| | | | 34,5 | 25,00 | 40 | | 0,77 |
| | 7,5 | 17,5 | 17,5 | 16,90 | 10 | 15,4 | 0,78 |
| | | | 21,7 | 27,00 | 16 | | 0,49 |
| | | 28,0 | 28,0 | 42,20 | 25 | | 0,31 |
| | | | 38,5 | 67,50 | 40 | | 0,20 |
| | | 52,5 | 101,00 | 60 | 0,13 | | |
| 0,8 | 4,0 | 12,6 | 2,66 | 10 | 39,9 | 12,70 | |
| | | 17,4 | 4,26 | 16 | | 8,00 | |
| | | 24,6 | 6,66 | 25 | | 5,10 | |
| | 5,5 | 15,0 | 15,0 | 6,40 | 10 | 30,2 | 4,00 |
| | | | 19,8 | 10,20 | 16 | | 2,50 |
| | | 27,0 | 27,0 | 16,00 | 25 | | 1,60 |
| | | | 39,0 | 25,60 | 40 | | 1,00 |
| | | 290,0 | 225,00 | 60 | 0,11 | | |
| | 9,0 | 20,6 | 20,6 | 21,40 | 10 | 19,0 | 0,76 |
| | | | 25,4 | 34,30 | 16 | | 0,47 |
| | | 32,6 | 32,6 | 53,50 | 25 | | 0,30 |
| | | | 44,6 | 85,60 | 40 | | 0,19 |
| | | 60,6 | 44,6 | 85,60 | 40 | | 0,19 |
| | | | 60,6 | 128,00 | 60 | | 0,13 |
| | 0,9 | 4,5 | 14,2 | 2,95 | 10 | 49,7 | 14,30 |
| 19,6 | | | 4,72 | 16 | 8,96 | | |
| 27,7 | | | 7,38 | 25 | 5,73 | | |
| 6,3 | | 17,1 | 17,1 | 7,43 | 10 | 37,1 | 4,23 |
| | | | 22,5 | 11,90 | 16 | | 2,65 |
| | | 30,6 | 30,6 | 18,60 | 25 | | 1,70 |
| | | | 44,1 | 29,70 | 40 | | 1,06 |
| 10,0 | | 23,0 | 23,0 | 23,10 | 10 | 24,0 | 0,88 |
| | | | 28,4 | 36,90 | 16 | | 0,55 |
| | | 36,5 | 36,5 | 57,60 | 25 | | 0,35 |
| | | | 50,0 | 92,20 | 40 | | 0,23 |
| | | 68,0 | 138,00 | 60 | 0,15 | | |

PRUŽINY

Tažné pružiny

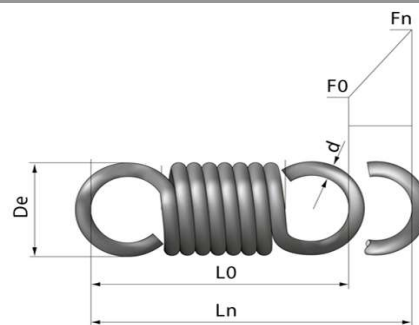

| TAŽNÉ PRUŽINY | | | | | | | |
|-------------------------------|---|--|---|----------------------------|---|-----------------------------------|-------|
| Průměr drátu d (mm) | Vnější průměr pružiny De (mm) | Délka pružiny v nezátženém stavu Lo (mm) | Prodloužení pružiny při max. deformaci Ln - Lo (mm) | Počet z závitů z | Síla potřebná pro max. deformaci pružiny Fn (N) | Tuhost pružiny c (N/mm) | |
| 1,0 | 5,0 | 15,8 | 3,25 | 10 | 60,8 | 15,90 | |
| | | 21,8 | 5,20 | 16 | | 9,90 | |
| | | 30,8 | 8,12 | 25 | | 6,37 | |
| | 7,0 | 19,0 | 8,17 | 10 | 45,3 | 4,71 | |
| | | 25,0 | 13,10 | 16 | | 2,94 | |
| | | 34,0 | 20,40 | 25 | | 1,83 | |
| | | 49,0 | 32,70 | 40 | | 1,18 | |
| | | 290,0 | 220,00 | 60 | | 0,18 | |
| | | 11,0 | 25,4 | 24,80 | | 10 | 29,6 |
| | 31,4 | 39,60 | 16 | 0,64 | | | |
| | 40,4 | 61,90 | 25 | 0,41 | | | |
| | 55,4 | 99,00 | 40 | 0,26 | | | |
| | 75,4 | 149,00 | 60 | 0,17 | | | |
| | 1,1 | 5,5 | 17,4 | 3,54 | 10 | 72,8 | 17,50 |
| | | | 24,0 | 5,66 | 16 | | 11,00 |
| 33,9 | | | 8,84 | 25 | 7,00 | | |
| 7,5 | | 20,6 | 8,30 | 10 | 55,5 | 5,69 | |
| | | 27,2 | 13,30 | 16 | | 3,55 | |
| | | 37,1 | 20,80 | 25 | | 2,28 | |
| | | 53,6 | 33,20 | 40 | | 1,42 | |
| 12,0 | | 27,8 | 26,40 | 10 | 35,8 | 1,15 | |
| | | 34,4 | 42,30 | 16 | | 0,72 | |
| | | 44,3 | 66,10 | 25 | | 0,46 | |
| | | 60,8 | 106,00 | 40 | | 0,28 | |
| | | 82,8 | 159,00 | 60 | | 0,20 | |
| 1,2 | 6,0 | 19,0 | 3,80 | 10 | 85,3 | 19,10 | |
| | | 26,2 | 6,08 | 16 | | 12,00 | |
| | | 37,0 | 9,50 | 25 | | 7,63 | |
| | 8,5 | 23,0 | 9,85 | 10 | 62,8 | 5,43 | |
| | | 30,2 | 15,80 | 16 | | 3,39 | |
| | | 41,0 | 24,60 | 25 | | 2,17 | |
| | | 59,0 | 39,60 | 40 | | 1,35 | |
| | | 290,0 | 225,00 | 60 | | 0,24 | |
| | 13,0 | 30,2 | 27,90 | 10 | 42,2 | 1,28 | |
| | | 37,4 | 44,70 | 16 | | 0,80 | |
| | | 48,2 | 69,80 | 25 | | 0,51 | |

PRUŽINY

Tažné pružiny

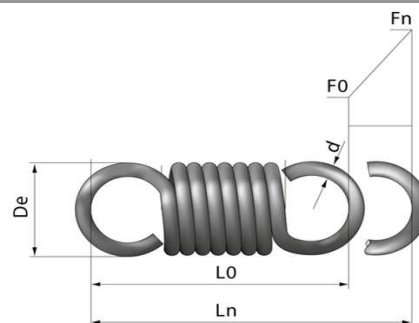

| TAŽNÉ PRUŽINY | | | | | | |
|-------------------------------|---|--|---|----------------------------|---|-----------------------------------|
| Průměr drátu d (mm) | Vnější průměr pružiny De (mm) | Délka pružiny v nezátženém stavu Lo (mm) | Prodloužení pružiny při max. deformaci Ln - Lo (mm) | Počet z závitů z | Síla potřebná pro max. deformaci pružiny Fn (N) | Tuhost pružiny c (N/mm) |
| 1,2 | 13,0 | 66,2 | 112,00 | 40 | 42,2 | 0,32 |
| | | 90,2 | 168,00 | 60 | | 0,21 |
| 1,4 | 7,0 | 22,1 | 4,36 | 10 | 114,0 | 22,30 |
| | | 30,5 | 6,98 | 16 | | 13,90 |
| | | 43,1 | 10,90 | 25 | | 8,91 |
| | 10,0 | 26,9 | 11,60 | 10 | 83,6 | 6,14 |
| | | 35,3 | 18,50 | 16 | | 3,83 |
| | | 47,9 | 28,90 | 25 | | 2,46 |
| | | 68,9 | 46,20 | 40 | | 1,54 |
| | 15,0 | 290,0 | 220,00 | 60 | | 0,32 |
| | | 34,9 | 31,20 | 10 | 57,1 | 1,55 |
| | | 43,3 | 50,00 | 16 | | 0,97 |
| 55,9 | | 78,10 | 25 | 0,62 | | |
| 76,9 | | 125,00 | 40 | 0,39 | | |
| 105,0 | 187,00 | 60 | 0,26 | | | |
| 1,5 | 7,5 | 23,7 | 3,90 | 10 | 109,0 | 23,88 |
| | | 32,7 | 6,20 | 16 | | 14,92 |
| | | 46,2 | 9,70 | 25 | | 9,55 |
| | 10,5 | 28,5 | 9,70 | 10 | 81,0 | 7,07 |
| | | 37,5 | 15,60 | 16 | | 4,42 |
| | | 51,0 | 24,30 | 25 | | 2,83 |
| | | 73,5 | 38,90 | 40 | | 1,77 |
| | 16,0 | 37,3 | 27,50 | 10 | 54,8 | 1,69 |
| | | 46,3 | 44,10 | 16 | | 1,06 |
| | | 59,8 | 68,80 | 25 | | 0,68 |
| 82,3 | | 110,10 | 40 | 0,42 | | |
| 112,3 | | 165,20 | 60 | 0,28 | | |
| 1,6 | 8,0 | 25,3 | 4,88 | 10 | 146,0 | 25,40 |
| | | 34,9 | 7,81 | 16 | | 15,90 |
| | | 49,3 | 12,20 | 25 | | 10,20 |
| | 11,0 | 30,1 | 11,70 | 10 | 111,0 | 8,04 |
| | | 39,7 | 18,70 | 16 | | 5,02 |
| | | 54,1 | 29,30 | 25 | | 3,22 |
| | | 78,1 | 46,80 | 40 | | 2,01 |
| | 17,0 | 39,7 | 34,30 | 10 | 74,0 | 1,82 |
| | | 49,3 | 54,80 | 16 | | 1,14 |

PRUŽINY

Tažné pružiny

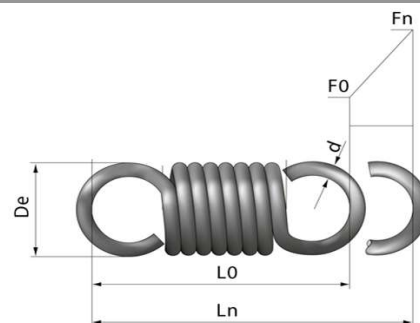

| TAŽNÉ PRUŽINY | | | | | | |
|----------------------------|--------------------------------------|--|--|-------------------------|--|--------------------------------|
| Průměr drátu d (mm) | Vnější průměr pružiny De (mm) | Délka pružiny v nezátíženém stavu Lo (mm) | Prodloužení pružiny při max. deformaci Ln - Lo (mm) | Počet z závitů z | Síla potřebná pro max. deformaci pružiny Fn (N) | Tuhost pružiny c (N/mm) |
| 1,6 | 17,0 | 63,7 | 85,60 | 25 | 74,0 | 0,73 |
| | | 87,7 | 137,00 | 40 | | 0,46 |
| | | 120,0 | 205,00 | 60 | | 0,30 |
| 1,8 | 9,0 | 28,4 | 5,37 | 10 | 180,0 | 28,60 |
| | | 39,2 | 8,59 | 16 | | 17,80 |
| | | 55,4 | 13,40 | 25 | | 11,50 |
| | 12,0 | 33,2 | 11,90 | 10 | 141,0 | 10,10 |
| | | 44,0 | 19,00 | 16 | | 6,28 |
| | | 60,2 | 29,70 | 25 | | 4,02 |
| | | 87,2 | 47,60 | 40 | | 2,52 |
| | | 290,0 | 175,00 | 60 | | 0,68 |
| | | 136,0 | 251,00 | 60 | | 0,29 |
| | 20,0 | 46,0 | 41,90 | 10 | 87,0 | 1,78 |
| | | 56,8 | 67,00 | 16 | | 1,11 |
| | | 73,0 | 105,00 | 25 | | 0,71 |
| 100,0 | | 167,00 | 40 | 0,44 | | |
| 136,0 | | 251,00 | 60 | 0,29 | | |
| 136,0 | | 251,00 | 60 | 0,29 | | |
| 2,0 | 10,0 | 31,6 | 5,86 | 10 | 220,0 | 31,80 |
| | | 43,6 | 9,38 | 16 | | 19,90 |
| | | 61,6 | 14,70 | 25 | | 12,80 |
| | 14,0 | 38,0 | 14,70 | 10 | 164,0 | 9,42 |
| | | 50,0 | 23,60 | 16 | | 5,88 |
| | | 68,0 | 36,90 | 25 | | 3,77 |
| | | 98,0 | 59,00 | 40 | | 2,35 |
| | 22,0 | 50,8 | 44,70 | 10 | 107,0 | 2,03 |
| | | 62,8 | 71,50 | 16 | | 1,27 |
| | | 80,8 | 112,00 | 25 | | 0,81 |
| | | 111,0 | 179,00 | 40 | | 0,51 |
| | | 151,0 | 268,00 | 60 | | 0,34 |
| 2,2 | 11,0 | 34,8 | 6,30 | 10 | 259,0 | 35,00 |
| | | 48,0 | 10,10 | 16 | | 21,90 |
| | | 67,8 | 15,80 | 25 | | 14,00 |
| | 15,0 | 41,2 | 14,80 | 10 | 198,0 | 11,40 |
| | | 54,4 | 23,70 | 16 | | 7,10 |
| | | 74,2 | 37,00 | 25 | | 4,55 |
| | | 107,0 | 59,20 | 40 | | 2,84 |
| | | 107,0 | 59,20 | 40 | | 2,84 |

PRUŽINY

Tažné pružiny

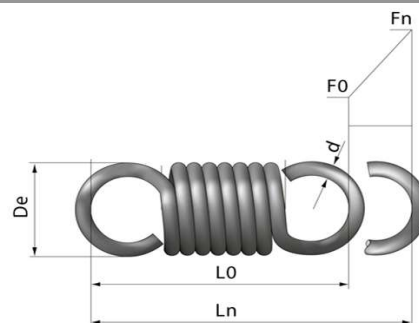

| TAŽNÉ PRUŽINY | | | | | | |
|-------------------------------|---|--|---|----------------------------|---|-----------------------------------|
| Průměr drátu d (mm) | Vnější průměr pružiny De (mm) | Délka pružiny v nezátženém stavu Lo (mm) | Prodloužení pružiny při max. deformaci Ln - Lo (mm) | Počet z závitů z | Síla potřebná pro max. deformaci pružiny Fn (N) | Tuhost pružiny c (N/mm) |
| 2,2 | 24,0 | 55,6 | 47,10 | 10 | 127,0 | 2,31 |
| | | 68,8 | 75,30 | 16 | | 1,44 |
| | | 88,6 | 118,00 | 25 | | 0,92 |
| | | 122,0 | 188,00 | 40 | | 0,58 |
| | | 166,0 | 282,00 | 60 | | 0,38 |
| 2,5 | 13,0 | 40,3 | 7,84 | 10 | 317,0 | 34,30 |
| | | 55,3 | 12,50 | 16 | | 21,50 |
| | | 77,8 | 19,60 | 25 | | 13,70 |
| | 18,0 | 48,3 | 18,90 | 10 | 237,0 | 10,70 |
| | | 63,3 | 30,30 | 16 | | 6,67 |
| | | 85,8 | 47,30 | 25 | | 4,27 |
| | | 123,0 | 75,70 | 40 | | 2,67 |
| | 28,0 | 64,3 | 55,60 | 10 | 157,0 | 2,39 |
| | | 79,3 | 88,90 | 16 | | 1,50 |
| | | 102,0 | 139,00 | 25 | | 0,96 |
| | | 139,0 | 222,00 | 40 | | 0,60 |
| | | 189,0 | 333,00 | 60 | | 0,40 |
| 2,8 | 14,0 | 44,2 | 7,65 | 10 | 400,0 | 44,60 |
| | | 61,0 | 12,20 | 16 | | 27,90 |
| | | 86,2 | 19,10 | 25 | | 17,90 |
| | 20,0 | 53,8 | 20,30 | 10 | 293,0 | 12,30 |
| | | 70,6 | 32,40 | 16 | | 7,68 |
| | | 95,8 | 50,60 | 25 | | 4,91 |
| | | 138,0 | 81,00 | 40 | | 3,07 |
| | 30,0 | 69,8 | 54,70 | 10 | 200,0 | 3,11 |
| | | 86,6 | 87,60 | 16 | | 1,94 |
| | | 112,0 | 137,00 | 25 | | 1,25 |
| | | 154,0 | 219,00 | 40 | | 0,78 |
| | | 210,0 | 328,00 | 60 | | 0,52 |
| 3,0 | 15,0 | 47,4 | 8,10 | 10 | 455,0 | 47,75 |
| | | 65,4 | 13,00 | 16 | | 29,85 |
| | | 92,4 | 20,20 | 25 | | 19,10 |
| | 21,0 | 57,0 | 20,40 | 10 | 339,5 | 14,15 |
| | | 75,0 | 32,60 | 16 | | 8,84 |
| | | 102,0 | 51,00 | 25 | | 5,66 |
| | | 147,0 | 81,60 | 40 | | 3,54 |

PRUŽINY

Tažné pružiny

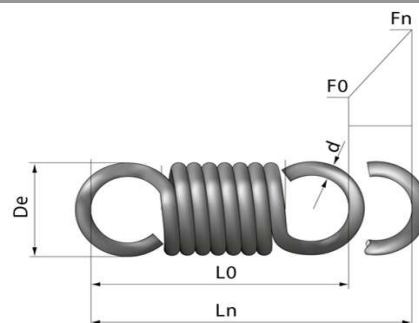

| TAŽNÉ PRUŽINY | | | | | | |
|----------------------------|--------------------------------------|--|--|-------------------------|--|--------------------------------|
| Průměr drátu d (mm) | Vnější průměr pružiny De (mm) | Délka pružiny v nezátíženém stavu Lo (mm) | Prodloužení pružiny při max. deformaci Ln - Lo (mm) | Počet z závitů z | Síla potřebná pro max. deformaci pružiny Fn (N) | Tuhost pružiny c (N/mm) |
| 3,0 | 33,0 | 76,2 | 61,60 | 10 | 221,5 | 3,06 |
| | | 94,2 | 98,60 | 16 | | 1,91 |
| | | 121,2 | 154,00 | 25 | | 1,22 |
| | | 166,2 | 246,40 | 40 | | 0,76 |
| | | 226,2 | 369,60 | 60 | | 0,51 |
| 3,2 | 12,8 | 50,6 | 8,52 | 10 | 510,0 | 50,90 |
| | | 69,8 | 13,60 | 16 | | 31,80 |
| | | 98,6 | 21,30 | 25 | | 20,40 |
| | 18,8 | 60,2 | 20,50 | 10 | 386,0 | 16,10 |
| | | 79,4 | 32,70 | 16 | | 10,00 |
| | | 108,0 | 51,10 | 25 | | 6,48 |
| | | 156,0 | 81,80 | 40 | | 4,02 |
| | 32,8 | 82,6 | 68,40 | 10 | 243,0 | 3,02 |
| | | 102,0 | 109,00 | 16 | | 1,89 |
| | | 131,0 | 171,00 | 25 | | 1,21 |
| | | 179,0 | 274,00 | 40 | | 0,76 |
| | | 243,0 | 410,00 | 60 | | 0,50 |
| 3,4 | 17,0 | 53,7 | 9,00 | 10 | 570,0 | 54,12 |
| | | 74,1 | 14,30 | 16 | | 33,83 |
| | | 104,7 | 22,40 | 25 | | 21,65 |
| | 23,0 | 63,3 | 20,20 | 10 | 429,5 | 18,08 |
| | | 83,7 | 32,30 | 16 | | 11,30 |
| | | 114,3 | 50,50 | 25 | | 7,23 |
| | | 165,3 | 80,80 | 40 | | 4,52 |
| | 38,0 | 87,3 | 70,70 | 10 | 273,5 | 3,29 |
| | | 107,7 | 113,20 | 16 | | 2,05 |
| | | 138,3 | 176,80 | 25 | | 1,31 |
| | | 189,3 | 282,90 | 40 | | 0,82 |
| | | 257,3 | 424,40 | 60 | | 0,55 |
| 3,6 | 18,0 | 56,9 | 9,35 | 10 | 630,0 | 57,20 |
| | | 78,5 | 15,00 | 16 | | 35,80 |
| | | 111,0 | 23,40 | 25 | | 22,90 |
| | 25,0 | 68,1 | 23,00 | 10 | 473,0 | 17,50 |
| | | 89,7 | 36,80 | 16 | | 10,90 |
| | | 122,0 | 57,60 | 25 | | 6,98 |
| | | 176,0 | 92,10 | 40 | | 4,37 |

PRUŽINY

Tažné pružiny

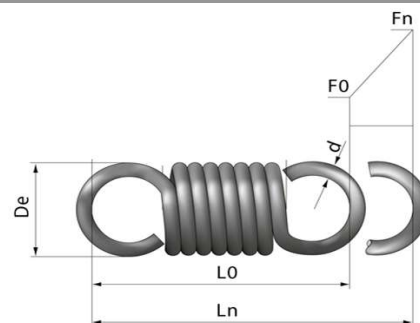

| TAŽNÉ PRUŽINY | | | | | | |
|----------------------------|--------------------------------------|--|--|-------------------------|--|--------------------------------|
| Průměr drátu d (mm) | Vnější průměr pružiny De (mm) | Délka pružiny v nezátíženém stavu Lo (mm) | Prodloužení pružiny při max. deformaci Ln - Lo (mm) | Počet z závitů z | Síla potřebná pro max. deformaci pružiny Fn (N) | Tuhost pružiny c (N/mm) |
| 3,6 | 40,0 | 92,1 | 72,90 | 10 | 304,0 | 3,54 |
| | | 114,0 | 117,00 | 16 | | 2,22 |
| | | 146,0 | 182,00 | 25 | | 1,42 |
| | | 200,0 | 292,00 | 40 | | 0,88 |
| | | 272,0 | 437,00 | 60 | | 0,59 |
| 3,75 | 19,05 | 59,7 | 10,50 | 10 | 693,5 | 56,25 |
| | | 82,2 | 16,80 | 16 | | 35,16 |
| | | 116,0 | 26,20 | 25 | | 22,50 |
| | 26,45 | 71,6 | 25,70 | 10 | 520,0 | 17,22 |
| | | 94,1 | 41,10 | 16 | | 10,76 |
| | | 127,8 | 64,20 | 25 | | 6,89 |
| | | 184,1 | 102,70 | 40 | | 4,31 |
| | 42,95 | 98,0 | 84,50 | 10 | 332,5 | 3,34 |
| | | 120,5 | 135,20 | 16 | | 2,09 |
| | | 154,2 | 211,30 | 25 | | 1,34 |
| | | 210,5 | 338,00 | 40 | | 0,84 |
| | | 285,5 | 507,00 | 60 | | 0,56 |
| 4,0 | 20,0 | 63,2 | 10,10 | 10 | 757,0 | 63,60 |
| | | 87,2 | 16,20 | 16 | | 39,70 |
| | | 123,0 | 25,30 | 25 | | 25,40 |
| | 28,0 | 76,0 | 25,40 | 10 | 564,0 | 18,80 |
| | | 100,0 | 40,70 | 16 | | 11,80 |
| | | 136,0 | 63,60 | 25 | | 7,54 |
| | | 196,0 | 102,00 | 40 | | 4,71 |
| | 45,0 | 103,0 | 81,20 | 10 | 361,0 | 3,78 |
| | | 127,0 | 130,00 | 16 | | 2,36 |
| | | 163,0 | 203,00 | 25 | | 1,51 |
| | | 223,0 | 325,00 | 40 | | 0,94 |
| | | 303,0 | 487,00 | 60 | | 0,63 |
| 4,25 | 21,05 | 66,8 | 10,40 | 10 | 854,0 | 70,10 |
| | | 92,3 | 16,60 | 16 | | 43,81 |
| | | 130,6 | 25,90 | 25 | | 28,04 |
| | 29,95 | 81,1 | 27,10 | 10 | 625,0 | 19,58 |
| | | 106,6 | 43,40 | 16 | | 12,24 |
| | | 144,8 | 67,80 | 25 | | 7,83 |
| | | 208,6 | 108,50 | 40 | | 4,90 |

PRUŽINY

Tažné pružiny

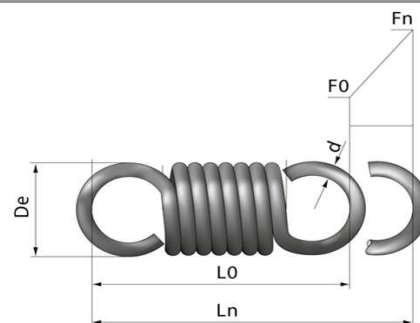

| TAŽNÉ PRUŽINY | | | | | | |
|----------------------------|--------------------------------------|--|--|-------------------------|--|--------------------------------|
| Průměr drátu d (mm) | Vnější průměr pružiny De (mm) | Délka pružiny v nezátíženém stavu Lo (mm) | Prodloužení pružiny při max. deformaci Ln - Lo (mm) | Počet z závitů z | Síla potřebná pro max. deformaci pružiny Fn (N) | Tuhost pružiny c (N/mm) |
| 4,25 | 47,55 | 109,2 | 84,30 | 10 | 406,0 | 4,09 |
| | | 134,7 | 134,90 | 16 | | 2,56 |
| | | 173,0 | 210,70 | 25 | | 1,64 |
| | | 236,7 | 337,20 | 40 | | 1,02 |
| | | 321,7 | 505,80 | 60 | | 0,68 |
| 4,5 | 22,0 | 70,3 | 10,40 | 10 | 951,0 | 77,90 |
| | | 97,3 | 16,60 | 16 | | 48,70 |
| | | 138,0 | 25,90 | 25 | | 31,20 |
| 4,5 | 32,0 | 86,3 | 29,00 | 10 | 685,0 | 20,10 |
| | | 113,0 | 46,40 | 16 | | 12,60 |
| | | 154,0 | 72,60 | 25 | | 8,03 |
| | | 221,0 | 116,00 | 40 | | 5,01 |
| | 50,0 | 115,0 | 86,40 | 10 | 451,0 | 4,43 |
| | | 142,0 | 138,00 | 16 | | 2,77 |
| | | 183,0 | 216,00 | 25 | | 1,78 |
| | | 250,0 | 346,00 | 40 | | 1,11 |
| 5,0 | 25,0 | 79,0 | 11,90 | 10 | 1110,0 | 79,50 |
| | | 109,0 | 19,00 | 16 | | 49,70 |
| | | 154,0 | 29,70 | 25 | | 31,80 |
| | 36,0 | 96,6 | 32,20 | 10 | 808,0 | 21,40 |
| | | 127,0 | 51,50 | 16 | | 13,30 |
| | | 172,0 | 80,40 | 25 | | 8,54 |
| | | 247,0 | 129,00 | 40 | | 5,34 |
| | 55,0 | 127,0 | 90,60 | 10 | 543,0 | 5,09 |
| | | 157,0 | 145,00 | 16 | | 3,18 |
| | | 202,0 | 226,00 | 25 | | 2,04 |
| | | 277,0 | 362,00 | 40 | | 1,28 |
| 377,0 | | 544,00 | 60 | 0,84 | | |